

## Application of corona electrical discharge plasma on modifying the physicochemical properties of banana starch indigenous to Taiwan

Follow this and additional works at: <https://www.jfda-online.com/journal>

 Part of the [Food Science Commons](#), [Medicinal Chemistry and Pharmaceutics Commons](#), [Pharmacology Commons](#), and the [Toxicology Commons](#)



This work is licensed under a [Creative Commons Attribution-Noncommercial-No Derivative Works 4.0 License](#).

### Recommended Citation

Wu, T.-Y.; Sun, N.-N.; and Chau, C.-F. (2018) "Application of corona electrical discharge plasma on modifying the physicochemical properties of banana starch indigenous to Taiwan," *Journal of Food and Drug Analysis*: Vol. 26 : Iss. 1 , Article 22.

Available at: <https://doi.org/10.1016/j.jfda.2017.03.005>

This Original Article is brought to you for free and open access by Journal of Food and Drug Analysis. It has been accepted for inclusion in Journal of Food and Drug Analysis by an authorized editor of Journal of Food and Drug Analysis.

Available online at [www.sciencedirect.com](http://www.sciencedirect.com)

ScienceDirect

journal homepage: [www.jfda-online.com](http://www.jfda-online.com)

## Original Article

# Application of corona electrical discharge plasma on modifying the physicochemical properties of banana starch indigenous to Taiwan



Tsung-Yen Wu <sup>a</sup>, Nan-Nong Sun <sup>a</sup>, Chi-Fai Chau <sup>a,b,\*</sup>

<sup>a</sup> Department of Food Science and Biotechnology, National Chung Hsing University, Taichung, Taiwan

<sup>b</sup> Agricultural Biotechnology Center, National Chung Hsing University, Taichung, Taiwan

## ARTICLE INFO

## Article history:

Received 23 January 2017

Received in revised form

14 March 2017

Accepted 17 March 2017

Available online 18 April 2017

## Keywords:

banana starch

corona electrical discharge

plasma

resistant starch

starch property

## ABSTRACT

Corona electrical discharge (CED) belongs to an atmospheric pressure cold plasma. In this study, raw banana starch (indigenous to Taiwan), which contained resistant starch and amylose at a level of 58.4 g/100 g and 14.5 g/100 g, respectively, was treated by CED at 30 kV/cm, 40 kV/cm, and 50 kV/cm for 3 minutes. After the CED treatment, starch analyses showed that there were no apparent changes in the resistant starch and amylose contents. Only surface and nonpenetrative damage caused by plasma etching at different voltage strengths were observed on the starch granules. The CED treatments reduced the total area of diffraction peak, gelatinization enthalpy (by –21% to –38%), and different pasting behaviors including peak viscosity, breakdown, final viscosity, and setback. The CED treatments were capable of increasing relative crystallinity and gelatinization temperature. This study revealed the potential of CED plasma technology as a tool to modify the characteristics of banana starch.

Copyright © 2017, Food and Drug Administration, Taiwan. Published by Elsevier Taiwan LLC. This is an open access article under the CC BY-NC-ND license (<http://creativecommons.org/licenses/by-nc-nd/4.0/>).

## 1. Introduction

Atmospheric pressure nonthermal plasmas (APNTPs), also termed “cold plasma,” is a plasma that is only slightly ionized (<1%). This can be operated at room temperature (290–300 K) without any quenching, and using it can avoid thermal degradation of thermosensitive materials. It provides a variety of electrical discharges such as corona electrical discharge (CED), dielectric barrier discharges, atmospheric pressure plasma jet, and micro hollow cathode discharges [1]. Among

all different applications of APNTPs, CED plasma is considered cost effective and relatively easy to operate [2].

APNTP has been applied in the food industry for various purposes, including decontamination of raw agricultural products (e.g., apple, lettuce, almond, mangoes, and melon), egg surface, and food system (e.g., cooked meat and cheese) [3]. APNTP is different from traditional thermal pasteurization. It could inactivate microbial enzymes and reduce the degradation of functional components in foods.

Some studies have shown that APNTP could affect the crystallinity of the solid starch granules [4] and improve

\* Corresponding author. Department of Food Science and Biotechnology, National Chung Hsing University, 145 Xingda Road, Taichung 40227, Taiwan.

E-mail address: [chaucf@nchu.edu.tw](mailto:chaucf@nchu.edu.tw) (C.-F. Chau).

<http://dx.doi.org/10.1016/j.jfda.2017.03.005>

1021-9498/Copyright © 2017, Food and Drug Administration, Taiwan. Published by Elsevier Taiwan LLC. This is an open access article under the CC BY-NC-ND license (<http://creativecommons.org/licenses/by-nc-nd/4.0/>).

dough strength [5,6]. APNTP-treated flour was found to have an increased stability, strength, deformation energy (W), and index of swelling [7]. Prolonged treatment time and higher applied voltage could improve viscosity and elastic modulus of wheat flour [6].

Native raw banana starch is rich in resistant starch. This makes it a good candidate to confer health benefits such as preventing postprandial blood sugar from rising rapidly. However, restriction of swelling and other physicochemical properties in resistant starch might also make the raw banana starch unfavorable for applications in moisture holding, thickening, and gel forming. Our recent research efforts have also revealed the potential of applying CED plasma technology as an alternative physical approach to modify the property of banana starch indigenous to Taiwan.

In this study, Taiwan's native banana starch was treated with CED plasma at different electrical field strengths. The aim was to improve the physicochemical properties and characteristics of banana starch by CED, and thus to increase its economic potential and industrial applications. Changes in  $\alpha$ -amylose and resistant starch contents were determined. The effects of CED plasma at different conditions on the physical functionality including morphological characterization, X-ray diffraction (XRD), thermal analysis, and pasting behavior of treated starch were also investigated.

## 2. Materials and methods

### 2.1. Materials

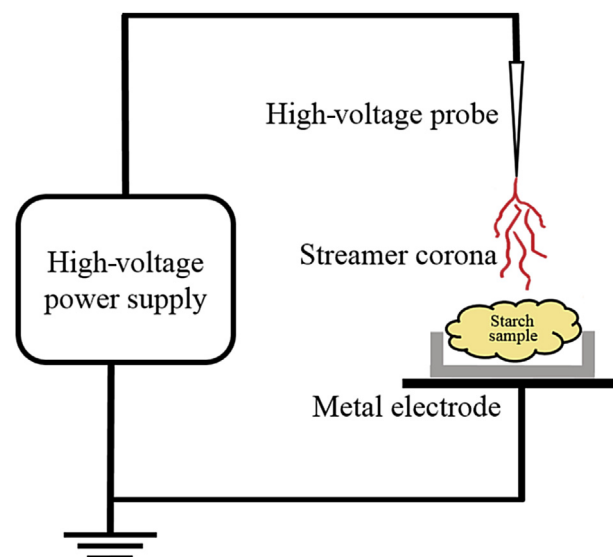
Green banana (Pei Chiao, AAA) was purchased from a local market in Wufeng, Taichung (Taiwan). The Taiwan's native banana starch was extracted according to the methods described by Aparicio-Saguilán et al [8] immediately after harvest.

### 2.2. CED treatments

Native banana starch suspension was prepared by mixing native banana starch in deionized water at a ratio of 1:3 (w/w) for 4 hours at 25°C. With reference to the methods described by Han et al [9], the suspension was treated with the CED system (TBA-HT3, YUSING Co., Ltd., Shizuoka, Japan) under a current intensity of 60 A at 30 kV/cm, 40 kV/cm, and 50 kV/cm for 3 minutes. A schematic diagram of the experimental setup is shown in Figure 1. After the CED treatments, the samples were immediately vacuum filtered and dried in an oven at 40°C for 24 hours. Dried starch samples were kept in a refrigerator at about 4°C before analysis.

### 2.3. Determination of amylose and resistant starch contents

Amylose content as a percentage of total starch was analyzed using the amylose/amylopectin assay kit manufactured by Megazyme International Ireland Ltd. (Bray, Ireland). Resistant starch content in the banana starch



**Figure 1 – Schematic diagram of the experimental setup using corona electrical discharge plasma as a tool to modify starch characteristics.**

sample was measured using the resistant starch assay kit developed by Megazyme International Ireland Ltd. (Bray, Ireland).

### 2.4. Morphological characterization

The morphology and birefringence patterns of banana starch samples were examined using a tabletop scanning electron microscope (SEM; TM-1000, Hitachi, Tokyo, Japan) and Nikon microscope (Optiphot 2-Pol, Nikon, Tokyo, Japan). Before SEM observation, samples were fixed on a specimen holder using double-face tape and sputter coated with gold (at 2 mbar for 3 minutes).

### 2.5. X-ray diffraction

The relative degree of crystallinity of banana starch samples was investigated by XRD (PW3040; Philips, Amsterdam, the Netherlands) operated at 40 kV and 30 mA with copper as a target. The diffracted intensity was measured from 4° to 60° as a function of  $2\theta$ , with a step angle of 0.013° at a scan rate of 1°/min. Percent crystallinity was calculated as the percentage of peak area in the total diffraction area.

### 2.6. Thermal analysis

The gelatinization properties of native and CED-treated banana starch samples were analyzed with a differential scanning calorimeter (DSC; Model Q20, TA Instruments, New Castle, DE, USA). Starch samples were sealed in an aluminum pan and mixed with deionized water at a ratio of 1:3 (w/w). After stabilization at 30°C for 5 minutes, the samples were further heated to 150°C at a rate of 10°C/min. The onset, peak, and conclusion temperatures ( $T_o$ ,  $T_p$ , and  $T_c$ , respectively) together with gelatinization enthalpy ( $\Delta H_{gel}$ ) were quantified.

## 2.7. Pasting behavior

Pasting behavior of samples was measured with a Rapid Visco Analyser (Model RVA-Super 3, Newport Scientific, Warriewood, NSW, Australia), which was controlled by the Thermocline software (version 2.3, Newport Scientific Pty Ltd.). A starch suspension sample prepared by mixing starch in deionized water at a ratio of 7:100 (w/w) was gradually heated (while being stirred at 160 rpm) from 50°C to 95°C at a rate of 7.5°C/min, and held at 95°C for 5 minutes. After that, the mixture was cooled from 95°C to 50°C at the same rate and then held at 50°C for 20 minutes. The viscosity of starch suspension samples was expressed by the rapid viscosity unit (RVU). The peak viscosity (maximum viscosity during pasting), breakdown viscosity (difference between the peak viscosity and minimum paste viscosity), setback viscosity (difference between the final viscosity and minimum viscosity during pasting), final viscosity, and pasting temperature were also determined.

## 2.8. Statistical analysis

The data represent a mean of at least three replicates. Significant difference was tested using analysis of variance/Fisher least-significant difference test ( $p < 0.05$ ) with SAS Enterprise Guide (SAS Institute Inc., Cary, NC, USA).

# 3. Results and discussion

## 3.1. Influences of CED on starch contents

CED is an emerging novel nonthermal and chemical-free technology for starch modification. Our results revealed that the resistant starch and amylose contents of native banana starch were 58.4 g/100 g and 14.5 g/100 g, respectively. As reported in some other studies [10,11], the resistant starch and amylose contents in other banana samples were found to be 47.3–57.2 g/100 g and 9.11–17.16 g/100 g, respectively. The high-resistant starch content makes the banana starch sample a good candidate to be used as an ingredient in slow-carbohydrate diet.

After the CED treatments at different electric field strengths (30 kV/cm, 40 kV/cm, and 50 kV/cm), the resistant starch (58.4 g/100 g) in the native banana starch sample was comparable to those (62.6 g/100 g, 60.5 g/100 g, and 62.6 g/100 g, respectively) in different CED-treated samples. No apparent changes in the amylose contents were observed in different banana starch samples before (14.5 g/100 g) and after the CED treatments (14.1–15.7 g/100 g). This study revealed that treating the banana starch samples with CED plasma did not alter their resistant starch and amylose levels.

## 3.2. Morphology of starch granules

The results of microscopic studies of green banana starches are shown in Figures 2 and 3. Banana starch granules were cylindrical, ellipsoid, and spherical, with diameters varying from 10  $\mu\text{m}$  to 60  $\mu\text{m}$ . As compared with the native banana

starch granule, a greater surface damage or roughness was observed on the granules after being subjected to the CED treatments at different voltage strengths (Figure 2). The surface damage was probably caused by the electrical current passing through the starch granules during the treatment with high-intensity plasma [12]. The treated granules appeared to be smaller and irregular in shape.

Under polarized light, the Maltese cross feature could be clearly seen in both the native and CED-treated banana starches (Figure 3). The CED-treated starches retained their Maltese cross features. It implied that these starch samples did not undergo a significant gelatinization and crystalline region breakdown in the nonthermal plasma treatment. These results agreed with some previous findings in which potato starch granules displayed negligible changes after glow-plasma treatment [13].

## 3.3. Scanning electron microscopy

The SEM micrographs of native and CED-treated banana starch granules are shown in Figure 4. The results in Figure 4A indicate that the surface morphology of native banana starch was smooth and irregular. After the CED treatment at 30 kV/cm, most starch granules basically retained their original shapes (Figure 4B), and some scraggly structures appeared on the granule's surface. After being treated at 40 kV/cm (Figure 4C), cavities appeared; meanwhile, some small particles aggregated together to form bigger starch piles on the surface. At a higher intensity (50 kV/cm), the banana starch surface was found to be distorted apparently (Figure 4D). These results demonstrated that the structures of native starch granules would be altered by different voltage strengths. It was inferred that the aggregation of small surface particles due to the Van der Waal's force and electrostatic force resulted in the rough surfaces of starch granules [14].

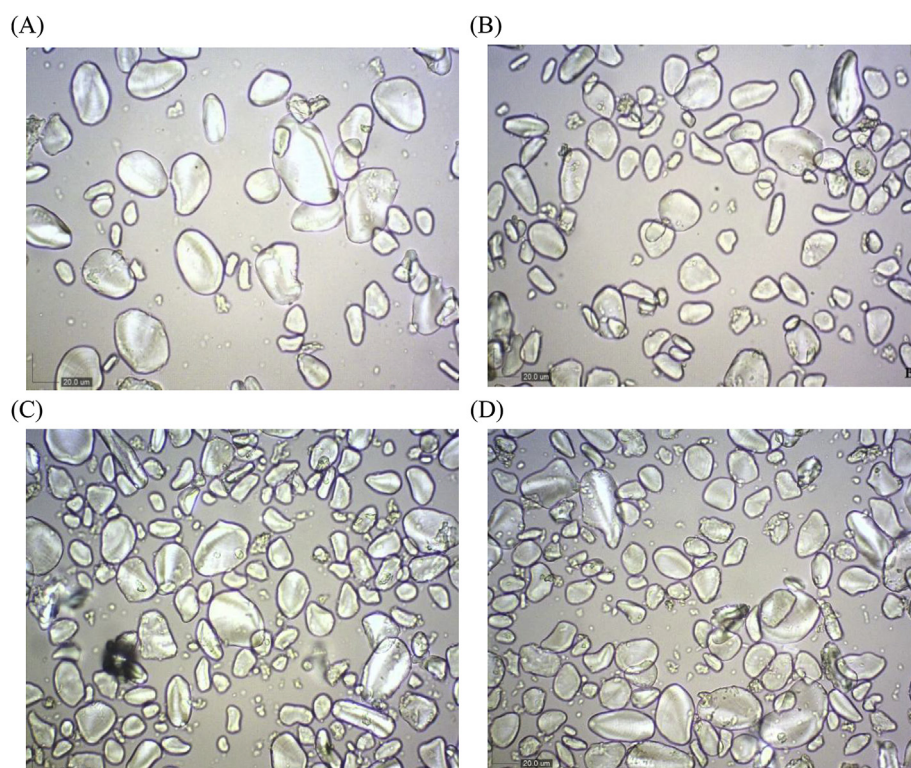
As the voltage strength increased, the surface rupture of banana starch granules becomes more severe and gradually they lose their original shapes. Superficial (nonpenetrative) damage was caused by plasma etching to different extents at various voltages. Han and colleagues [9] have reported that use of pulsed electric fields treatment on corn starch might cause damage on the protective envelope of starch granules, thus assisting further penetrative damage and resulting in better water-absorbing and swelling abilities.

## 3.4. XRD pattern

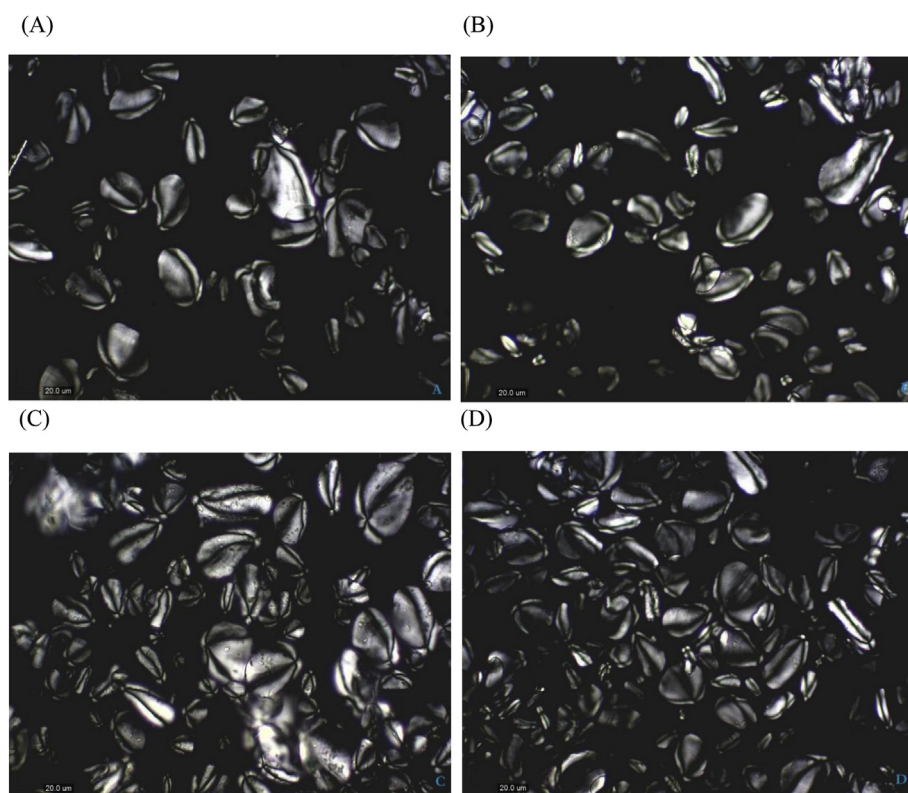
The XRD patterns of native and different CED-treated starch samples are shown in Figure 5. In agreement with the findings from Lii and coworkers [15], the native banana starch with its main peaks appearing at 5°, 17°, 18°, 22°, and 24° ( $2\theta$ ) indicated that its structure belonged to the B-pattern, and its relative crystallinity was 20.4%. After different CED treatments, significant ( $p < 0.05$ ) increases in the peak intensity were observed at around 5°, 17°, 18°, 22°, and 24° ( $2\theta$ ), representing an apparent alteration of crystalline region.

The relative crystallinities of the native starch and three CED-treated starches (at 30 kV/cm, 40 kV/cm, and 50 kV/cm) were 20.4%, 21.2%, 22.3%, and 24.6%, respectively (Figure 5). An

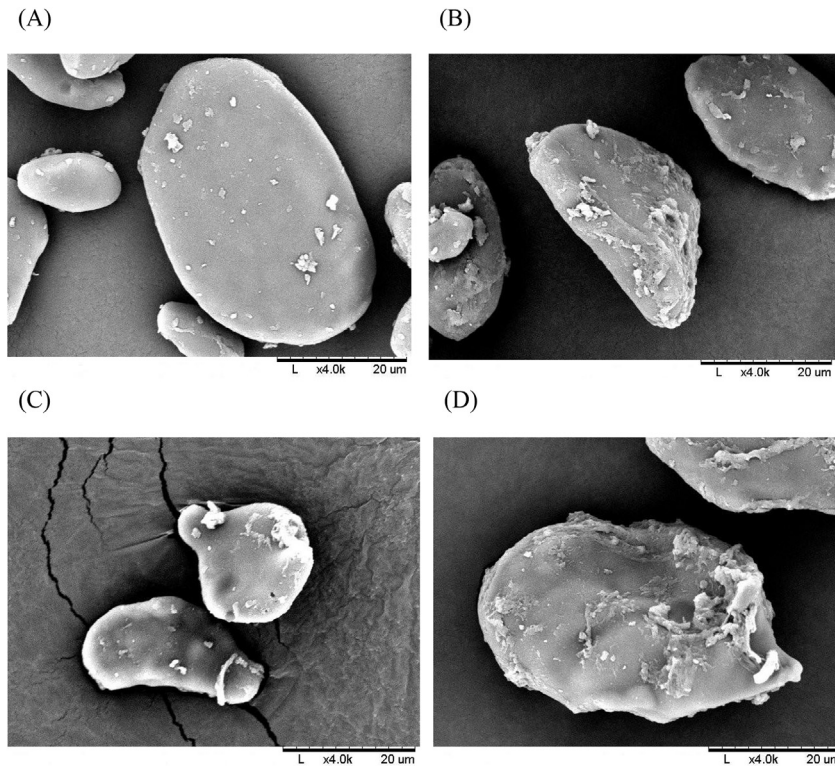




**Figure 2 – Photographs of the Taiwan's native and corona electrical discharge-treated banana starches under normal light: (A) native; (B) 30 kV/cm; (C) 40 kV/cm; (D) 50 kV/cm.**



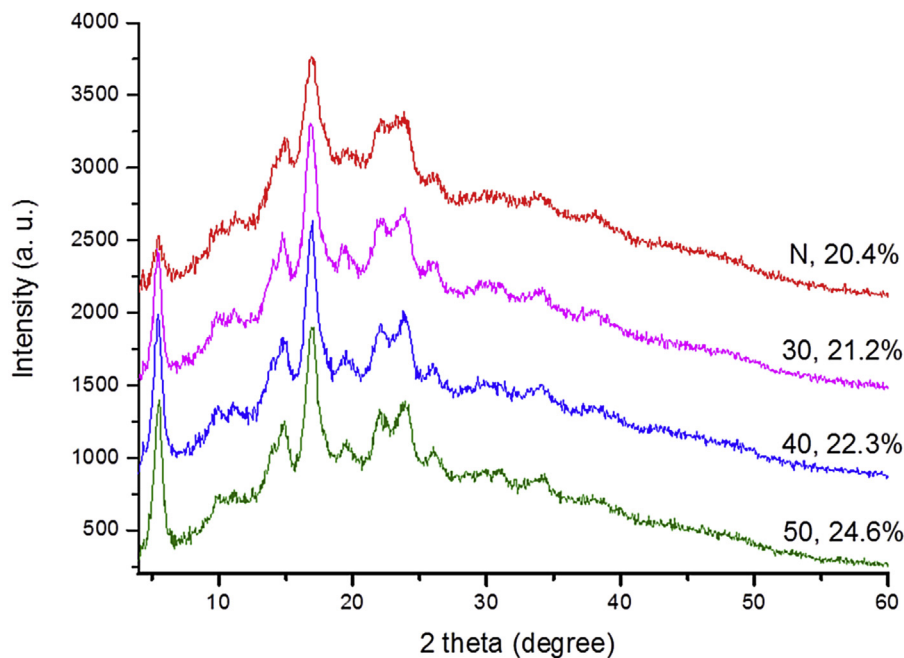
**Figure 3 – Photographs of the Taiwan's native and corona electrical discharge-treated banana starches under polarized light: (A) native; (B) 30 kV/cm; (C) 40 kV/cm; (D) 50 kV/cm.**



**Figure 4 – Scanning electron microscopic micrographs of the Taiwan's native and corona electrical discharge-treated banana starches: (A) native; (B) 30 kV/cm; (C) 40 kV/cm; (D) 50 kV/cm.**

elevation in relative crystallinity after an intense CED treatment agreed with the observations made by Zhang et al [4]. Cold plasma may produce free radicals and reactive oxygen species including hydroxyl radicals, hydrogen peroxide, and

superoxide anion. Upon CED treatment, starch granules might be modified by the free radicals and energetic electrons formed during plasma generation, which resulted in a phenomenon of crosslinking between the polymeric chains of



**Figure 5 – X-ray power diffraction patterns of the Taiwan's native and corona electrical discharge-treated banana starches. N = native; 30 = 30 kV/cm; 40 = 40 kV/cm; 50 = 50 kV/cm.**

starch molecules [16,17]. Moreover, the dehydroxylation of starch amorphous region through condensation and ether bond formation at certain temperature might cause the starch molecules to be rearranged in a more orderly form and closer to the crystalline region, resulting in an increase of relative crystallinity [18].

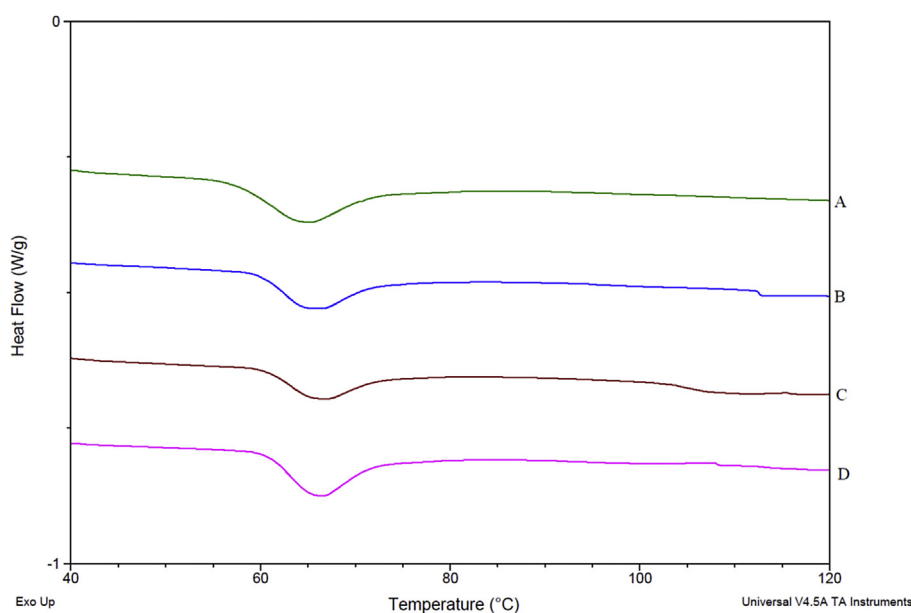
In the XRD spectrum as illustrated in Figure 5, a ratio of crystalline phase to amorphous phase could be used to describe the extent of crystallization of polymers. The crystalline-to-amorphous ratio at different voltage strengths (30 kV/cm, 40 kV/cm, and 50 kV/cm) was found in an ascending order (0.269, 0.286, and 0.326, respectively), whereas that of the native starch was only 0.256. After the CED treatment, new connections were formed within the structure of banana starches, which might lead to an increase in their crystalline-to-amorphous ratios as well as their relative crystallinity and gelatinization temperature.

### 3.5. Thermal analysis

The DSC thermograms of different starch samples are shown in Figure 6. The gelatinization temperatures (including onset,  $T_0$ ; peak,  $T_p$ ; and conclusion,  $T_c$ ) and  $\Delta H_{\text{gel}}$  are listed in Table 1.

Compared with the  $T_0$  value of native banana starch (57.2°C), those of the CED-treated starches increased markedly ( $p < 0.05$ ) to 60.0°C, 60.5°C, and 61.2°C at 30 kV/cm, 40 kV/cm, and 50 kV/cm, respectively. Significant ( $p < 0.05$ ) increases in  $T_p$  values (66.0°C and 66.5°C) were also observed at 40 kV/cm and 50 kV/cm, respectively, in relation to their control  $T_p$  value (64.7°C).

Gelatinization enthalpies measured by the DSC were related to the intensity of crystallinity in starch granules [19]. As shown in Table 1, the  $\Delta H_{\text{gel}}$  values of the CED-treated banana starch samples decreased significantly ( $p < 0.05$ ) from 4.7 J/g (control) to 3.7 J/g at the voltage of 30 kV/cm, and further lowering to 3.1 J/g at a higher voltage (40 kV/cm).



**Figure 6** – Differential scanning calorimetry thermograms of the gelatinization properties among the Taiwan's native and corona electrical discharge-treated banana starches: (A) native; (B) 30 kV/cm; (C) 40 kV/cm; (D) 50 kV/cm.

**Table 1** – Different gelatinization properties of the Taiwan's native and corona electrical discharge-treated banana starches.

Treatments	$T_0$ (°C)	$T_p$ (°C)	$T_c$ (°C)	$\Delta H$ (J/g)
Native	57.2 <sup>c</sup>	64.7 <sup>c</sup>	72.1 <sup>b</sup>	4.7 <sup>a</sup>
30 kV/cm	60.0 <sup>b</sup>	65.5 <sup>b,c</sup>	72.8 <sup>b</sup>	3.7 <sup>b</sup>
40 kV/cm	60.5 <sup>b</sup>	66.0 <sup>a,b</sup>	72.3 <sup>b</sup>	3.1 <sup>c</sup>
50 kV/cm	61.2 <sup>a</sup>	66.5 <sup>a</sup>	72.3 <sup>b</sup>	2.9 <sup>c</sup>

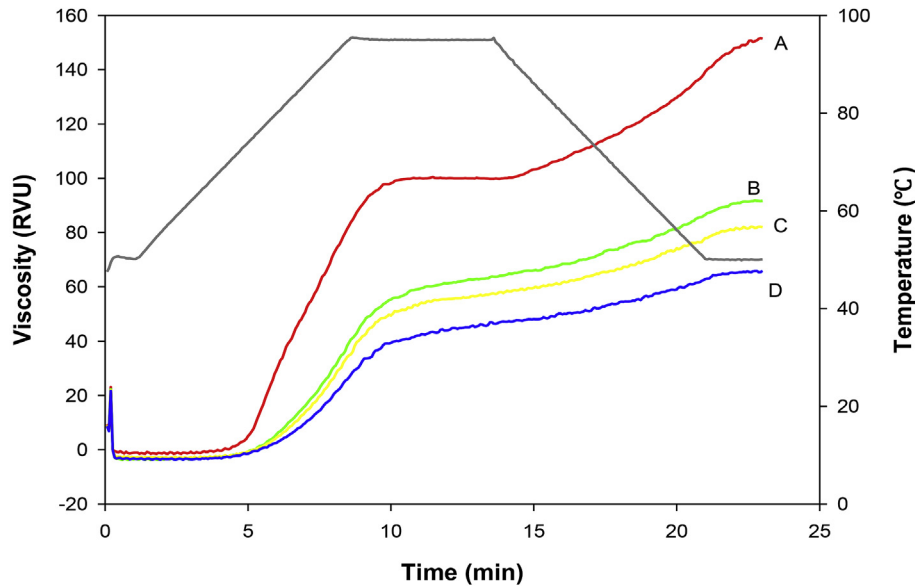
All data represent the mean of three determinations. Means with different letters in each column are significantly different ( $p < 0.05$ ).

Based on the XRD analysis (Figure 5), the decrease in  $\Delta H_{\text{gel}}$  of gelatinization was probably attributed to the reduction in the total area of diffraction peak at a higher CED intensity. Moreover, it has also been reported that this loss of enthalpy might be accompanied by an increase in onset and peak temperatures ( $T_0$  and  $T_p$ , respectively), and increase in annealing time of starch gelatinization [20]. The understanding of annealing effects on the starch texture and viscosity is important to make a better quality of starch foods [21]. In this study, it was revealed that the application of CED treatments was capable of elevating the gelatinization temperature.

### 3.6. Pasting behavior

Viscoamylograms of different banana starch samples are shown in Figure 7, and their whole pasting behaviors are summarized in Table 2. The CED treatments could significantly ( $p < 0.05$ ) reduce the peak viscosity (maximum viscosity during pasting) from 100.4 RVU (control) to 61.4–44.4 RVU (at 30–50 kV/cm). The peak viscosity decreased with increasing voltage strength, with the lowest value (44.4 RVU) being observed at 50 kV/cm.





**Figure 7 – Rapid Visco Analyser viscosity of the Taiwan's native and corona electrical discharge-treated banana starches: (A) native; (B) 30 kV/cm; (C) 40 kV/cm; (D) 50 kV/cm. RVU = rapid viscosity unit.**

A significant drop in the breakdown viscosity was found in the CED-treated banana starch. Breakdown viscosity was used to examine the response of starches to shear thinning [22]. As shown in Table 2, the CED-treated banana starches exhibited a good resistance to shear thinning during heating, as indicated by their low breakdown viscosity. Higher breakdown viscosity implied that the sample might undergo a higher degree of swelling and subsequent disintegration [23]; in other words, the CED treatment was able to effectively reduce the swelling power of banana starch.

All three CED treatments were able to significantly ( $p < 0.05$ ) increase the pasting temperatures to 88.8–92.1°C from the control value (74.4°C; Table 2). The higher pasting temperature was associated with a higher crystallinity of starch [24] and also a higher resistance toward swelling [25]. These results again supported the observations of higher crystallinity at higher voltage strengths in Figure 5.

Setback values were defined as degree of reassociation between the starch molecules involving amylase [26]. In Table 2, the native banana starch was found to have the highest setback value (51.7 RVU), which was higher than those of the CED-treated banana starches (21.5–30.4 RVU). Typically, starch with a higher setback value had a greater tendency for retrogradation [27]. CED treatment might therefore help

reduce the degree of retrogradation and improve the paste-cooling stability of banana starch.

Overall, the peak, breakdown, final viscosity, and setback of treated starch decreased with increasing voltage strength. Our results suggested that the CED treatment could be considered as a promising method to modify properties of starch. It could be applied in various food products (e.g., frozen foods, sauces, baked goods) as well as starch ingredients requiring lower viscosity and higher gelatinization temperature.

Based on the findings in this study, there were no apparent changes in the resistant starch and amylose contents after the CED treatments, and only surface damage was found on the starch granules. The results showed that CED treatment did not result in an apparent breakdown of crystalline regions and penetrational damage of banana starch. We also observed a reduction in the total area of diffraction peak, gelatinization enthalpy, and different pasting behaviors. CED treatments were capable of increasing relative crystallinity and gelatinization temperature. This study revealed the potential of CED plasma technology as a tool to modify the characteristics of Taiwan's native banana starch and increase its economic potential. It was also believed that this novel technique could be applied to other types of starches.

**Table 2 – Viscosity behaviours of the Taiwan's native and corona electrical discharge-treated banana starches.**

Treatments	Peak viscosity (RVU)	Breakdown (RVU)	Final viscosity (RVU)	Setback (RVU)	Pasting temperature (°C)
Native	100.4 <sup>a</sup>	0.7 <sup>a</sup>	151.4 <sup>a</sup>	51.7 <sup>a</sup>	74.4 <sup>c</sup>
30 kV/cm	61.4 <sup>b</sup>	0.0 <sup>b</sup>	91.7 <sup>b</sup>	30.4 <sup>b</sup>	88.8 <sup>b</sup>
40 kV/cm	55.5 <sup>c</sup>	0.1 <sup>b</sup>	81.9 <sup>c</sup>	26.5 <sup>c</sup>	90.7 <sup>b</sup>
50 kV/cm	44.4 <sup>d</sup>	0.1 <sup>b</sup>	65.8 <sup>d</sup>	21.5 <sup>d</sup>	92.1 <sup>a</sup>

All data represent the mean of three determinations. Means with different letters in each column are significantly different ( $p < 0.05$ ). RVU = rapid viscosity unit.



---

## Conflicts of interest

All contributing authors declare no conflicts of interest.

---

## Acknowledgments

This work was supported by the Council of Agriculture, the Republic of China (105AS-16.3.1-CI-C5 and 105AS-16.3.1-CI-C6).

---

## REFERENCES

- [1] Nehra V, Kumar A, Dwivedi H. Atmospheric non-thermal plasma sources. *Int J Eng* 2008;2:53–68.
- [2] Chang JS, Lawless PA, Yamamoto T. Corona discharge processes. *IEEE Trans Plasma Sci* 1991;19:1152–66.
- [3] Deng S, Ruan R, Mok CK, Huang G, Lin X, Chen P. Inactivation of *Escherichia coli* on almonds using nonthermal plasma. *J Food Sci* 2007;72:M62–6.
- [4] Zhang B, Xiong S, Li X, Li L, Xie F, Chen L. Effect of oxygen glow plasma on supramolecular and molecular structures of starch and related mechanism. *Food Hydrocolloid* 2014;37:69–76.
- [5] Misra NN, Keener KM, Bourke P, Mosnier JP, Cullen PJ. In-package atmospheric pressure cold plasma treatment of cherry tomatoes. *J Biosci Bioeng* 2014;118:177–82.
- [6] Bahrami N, Bayliss D, Chope G, Penson S, Pehinec T, Fisk ID. Cold plasma: a new technology to modify wheat flour functionality. *Food Chem* 2016;202:247–53.
- [7] Menkovska M, Mangova M, Dimitrov K. Effect of cold plasma on wheat flour and bread making quality. *Maced J Anim Sci* 2014;4:27–30.
- [8] Aparicio-Saguilán A, Sayago-Ayerdi SG, Vargas-Torres A, Tovar J, Ascencio-Otero TE, Bello-Pérez LA. Slowly digestible cookies prepared from resistant starch-rich lintnerized banana starch. *J Food Comp Anal* 2007;20:175–81.
- [9] Han Z, Zeng XA, Zhang BS, Yu SJ. Effects of pulsed electric fields (PEF) treatment on the properties of corn starch. *J Food Eng* 2009;93:318–23.
- [10] Eggleston G, Swennen R, Akoni S. Physicochemical studies on starches isolated from plantain cultivars, plantain hybrids and cooking bananas. *Starch* 1992;44:121–8.
- [11] Faisant N, Buleon A, Colonna P, Molis C, Lartigue S, Galmiche J, et al. Digestion of raw banana starch in the small intestine of healthy humans: structural features of resistant starch. *Br J Nutr* 1995;73:111–23.
- [12] Barbosa-Canovas GV, Zhang QH, Pierson MD, Schaffner DW. High voltage arc discharge. *J Food Sci* 2000;65:80–1.
- [13] Zhang B, Chen L, Li X, Li L, Zhang H. Understanding the multi-scale structure and functional properties of starch modulated by glow-plasma: a structure-functionality relationship. *Food Hydrocolloid* 2015;50:228–36.
- [14] Werth J, Linsenbühler M, Dammer S, Farkas Z, Hinrichsen H, Wirth KE, et al. Agglomeration of charged nanopowders in suspensions. *Powder Technol* 2003;133:106–12.
- [15] Lii CY, Chang SM, Young YL. Investigation of the physical and chemical properties of banana starches. *J Food Sci* 1982;47:1493–7.
- [16] Thirumdas R, Sarangapani C, Annapure US. Cold plasma: a novel non-thermal technology for food processing. *Food Biophys* 2015;10:1–11.
- [17] Thirumdas R, Kadam D, Annapure US. Cold plasma: an alternative technology for the starch modification. *Food Biophys* 2017;12:129–39.
- [18] Khorram S, Zakerhamidi M, Karimzadeh Z. Polarity functions' characterization and the mechanism of starch modification by DC glow discharge plasma. *Carbohydr Polym* 2015;127:72–8.
- [19] Singh N, Singh J, Kaur L, Sodhi NS, Gill BS. Morphological, thermal and rheological properties of starches from different botanical sources. *Food Chem* 2003;81:219–31.
- [20] Knutson C. Annealing of maize starches at elevated temperatures. *Cereal Chem* 1990;67:376–84.
- [21] Tsutsui K, Katsuta K, Matoba T, Takemasa M, Funami T, Sato E, et al. Effects of time and temperature of annealing on rheological and thermal properties of rice starch suspensions during gelatinization. *J Texture Stud* 2013;4:21–33.
- [22] Massaux C, Sindic M, Lenartz J, Sinnavee G, Bodson B, Falisse A, et al. Variations in physicochemical and functional properties of starches extracted from European soft wheat (*Triticum aestivum* L.): the importance to preserve the varietal identity. *Carbohydr Polym* 2008;71:32–41.
- [23] Abera S, Rakshit SK. Processing technology comparison of physicochemical and functional properties of cassava starch extracted from fresh root and dry chips. *Starch* 2003;55:287–96.
- [24] Yuan Y, Zhang L, Dai Y, Yu J. Physicochemical properties of starch obtained from *Dioscorea nipponica* Makino comparison with other tuber starches. *J Food Eng* 2007;82:436–42.
- [25] Seetharaman K, Tziotis A, Borrás F, White P, Ferrer M, Robutti J. Thermal and functional characterization of starch from Argentinean corn. *Cereal Chem* 2001;78:379–86.
- [26] Charles AL, Chang YH, Ko WC, Sriroth K, Huang TC. Some physical and chemical properties of starch isolates of cassava genotypes. *Starch* 2004;56:413–8.
- [27] Zaidul I, Norulaini NN, Omar AM, Yamauchi H, Noda T. RVA analysis of mixtures of wheat flour and potato, sweet potato, yam, and cassava starches. *Carbohydr Polym* 2007;69:784–91.